

# CS330: Operating Systems

Process API: System calls

# Recap: The process abstraction

- The OS creates a process when we run an executable

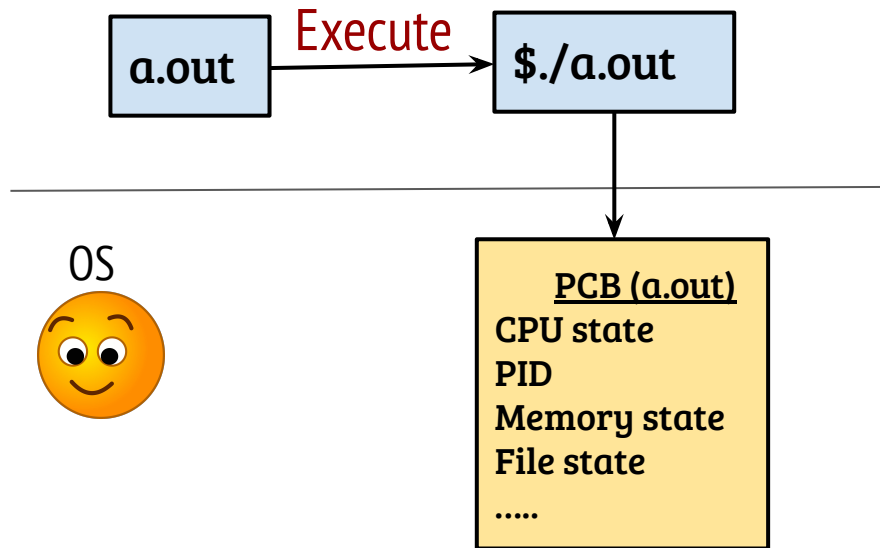

- When we execute “a.out” on a shell a process control block (PCB) is created
- Does it raise some questions related to the exact working?

# Process creation: What and How?

- How does OS come into action after typing “./a.out” in a shell?



# System call

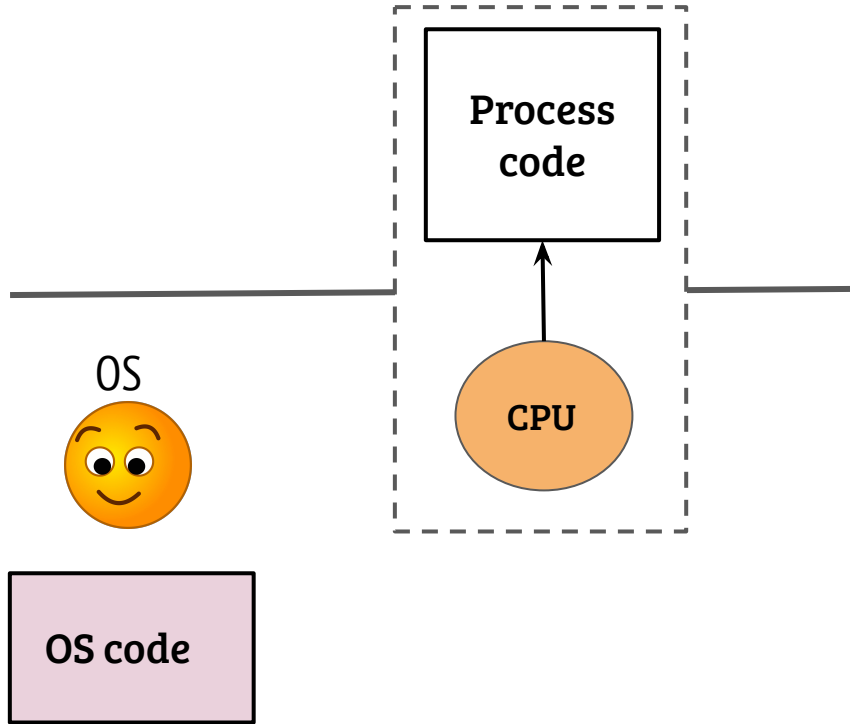

- CPU executing *user code* can invoke the *OS functions* using system calls

# System call

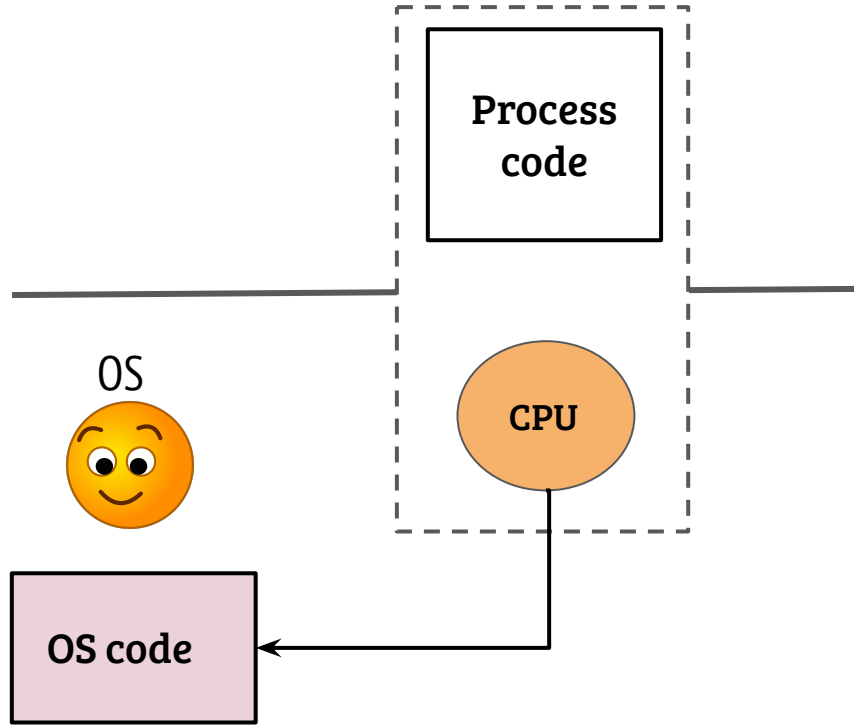

- CPU executing *user code* can invoke the *OS functions* using system calls
- The CPU executes the OS handler for the system call

# System call

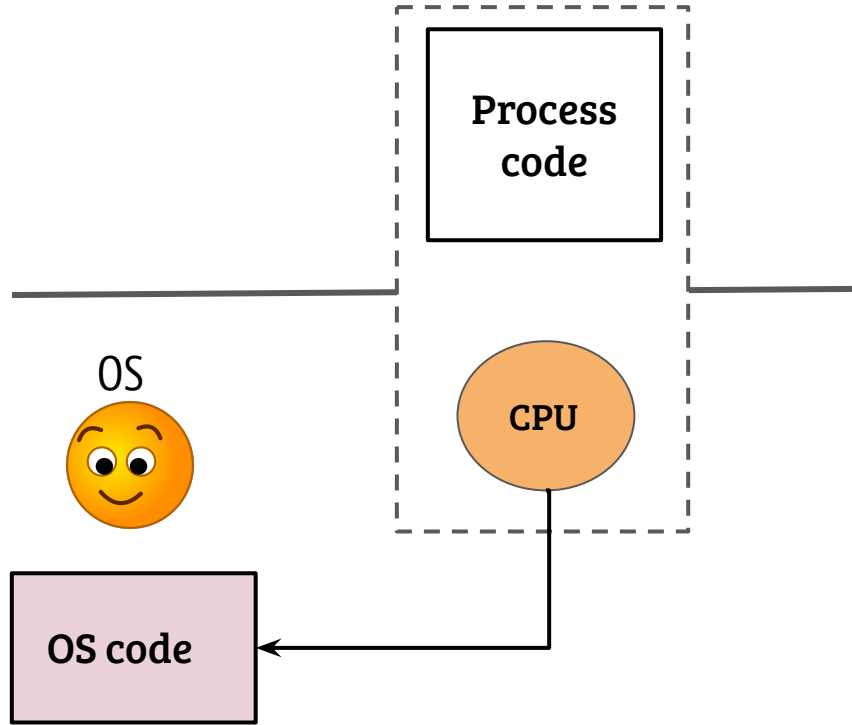

- CPU executing *user code* can invoke the *OS functions* using system calls
- The CPU executes the OS handler for the system call
- How system call is different from a function call?

# System call

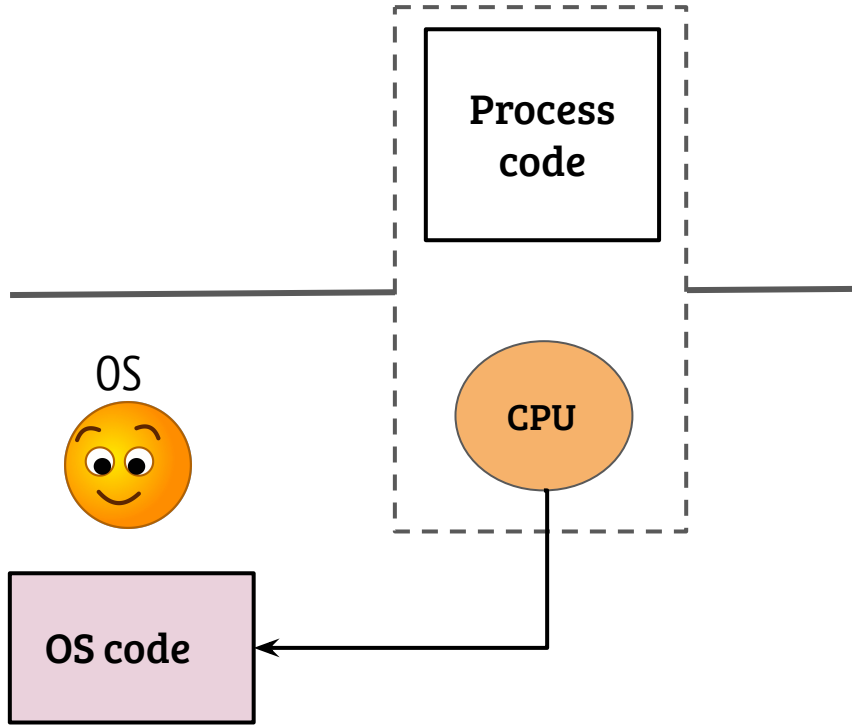

- CPU executing *user code* can invoke the *OS functions* using system calls
- The CPU executes the OS handler for the system call
- How is system call different from a function call?
- Can be thought as an invocation of privileged functions (will revisit)

# System calls and user libraries

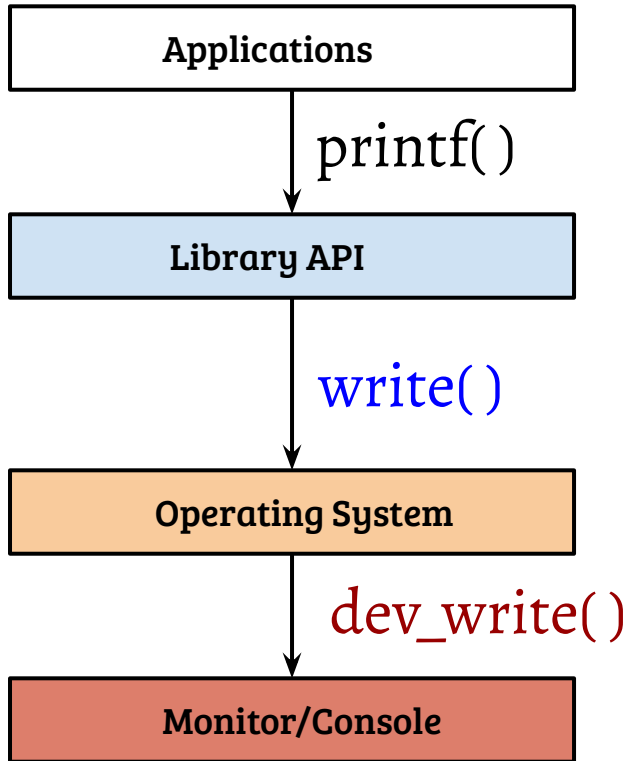

- Most system calls are invoked through wrapper library functions
- However, all system calls can be invoked directly
  - For example, in Linux systems, `syscall( )` wrapper can be used (Refer: `man syscall`)



# A simple system call: getpid( )

USER



```
main()  
{  
    printf(“%d\n”, getpid());  
}
```

pid\_t getpid( )

{

PCB \*current = get\_current\_process( );

return (current → pid);

}

OS



# Process creation: What and How?

- How does OS come into action after typing “./a.out” in a shell?
  - System calls invoked to explicitly give control to the OS
  - What exact system calls are invoked?
- 

# Process creation - fork( )

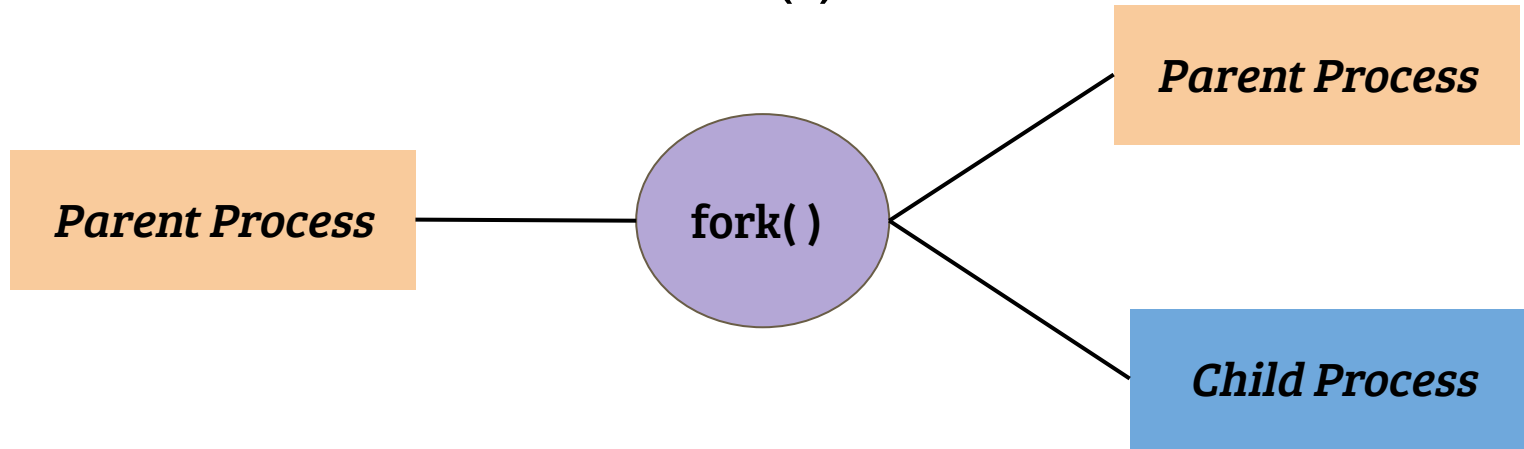

- fork( ) system call is weird; not a typical “privileged” function call
- fork( ) creates a new process; a *duplicate* of calling process
- On success, fork
  - Returns PID of child process to the caller (parent)
  - Returns 0 to the child

# Typical implementation of fork

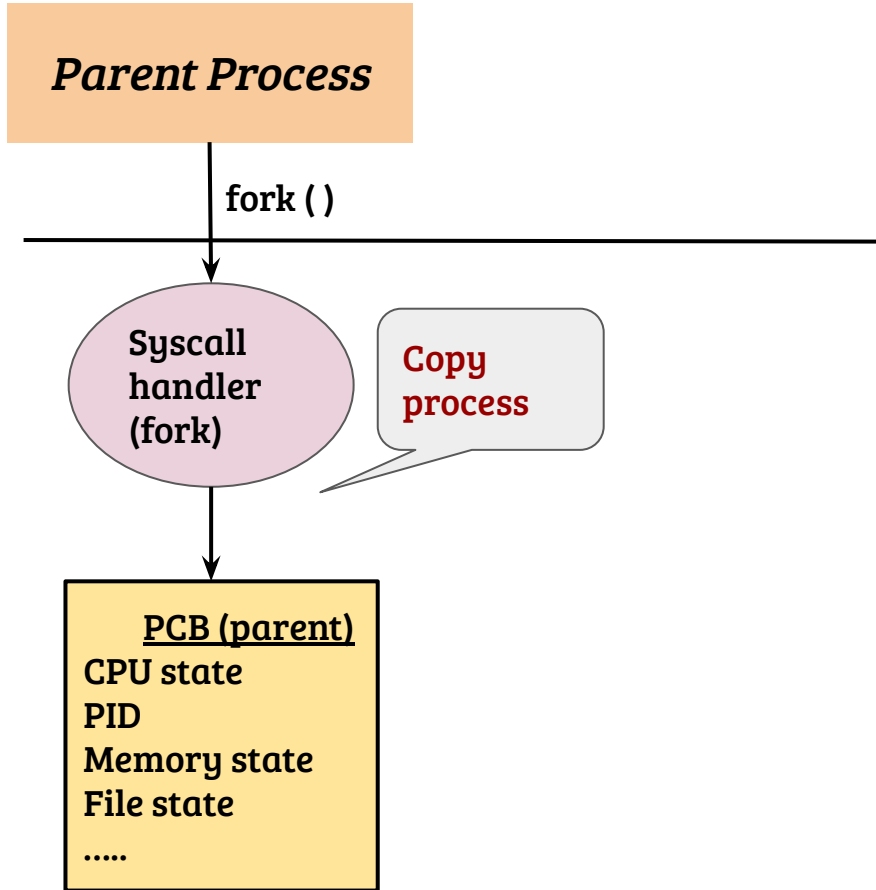

# Typical implementation of fork

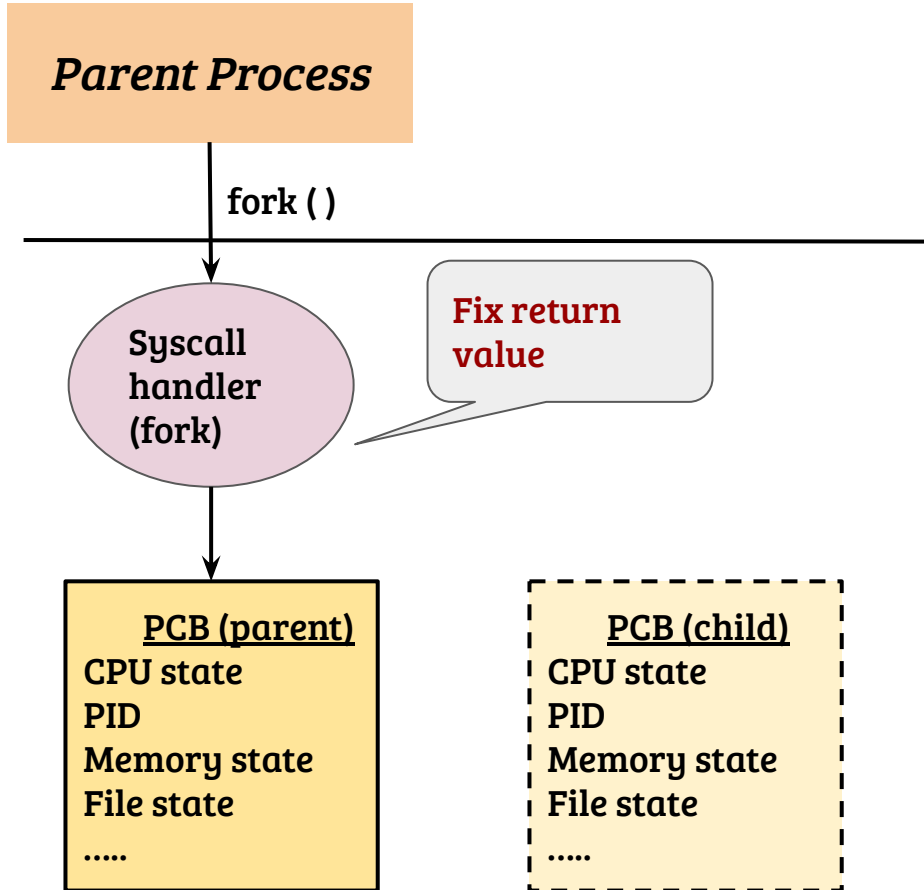

- Child should get '0' and parent gets PID of child as return value. How?

# Typical implementation of fork

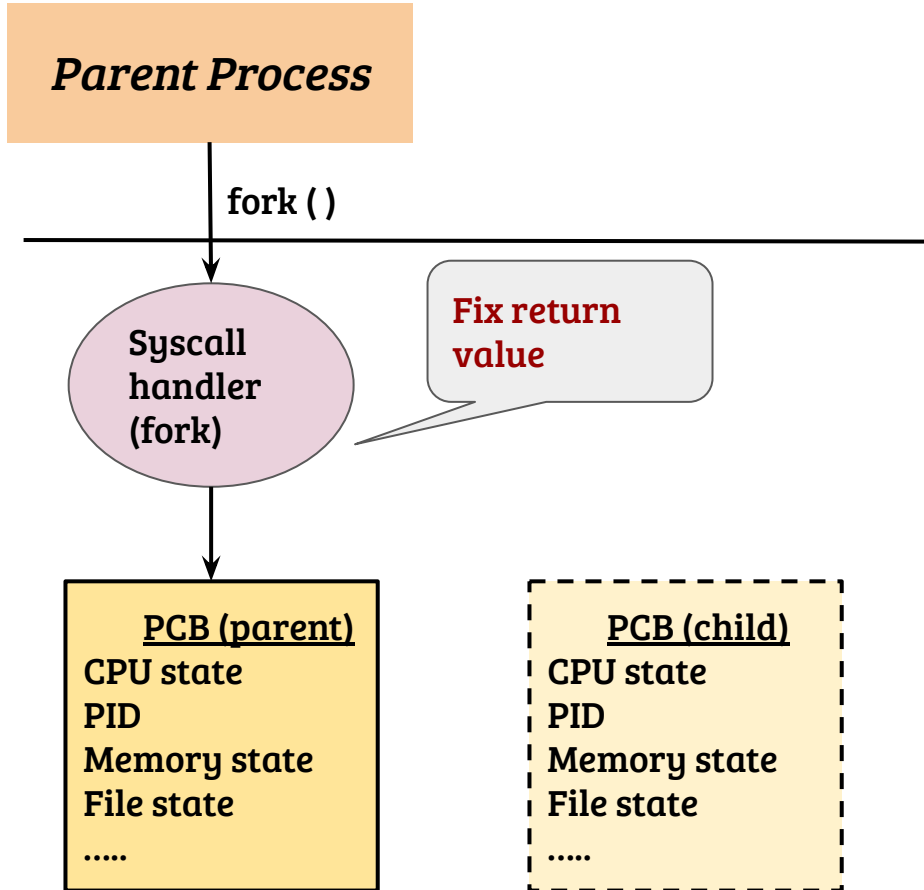

- Child should get '0' and parent gets PID of child as return value. How?
- OS returns different values for parent and child

# Typical implementation of fork

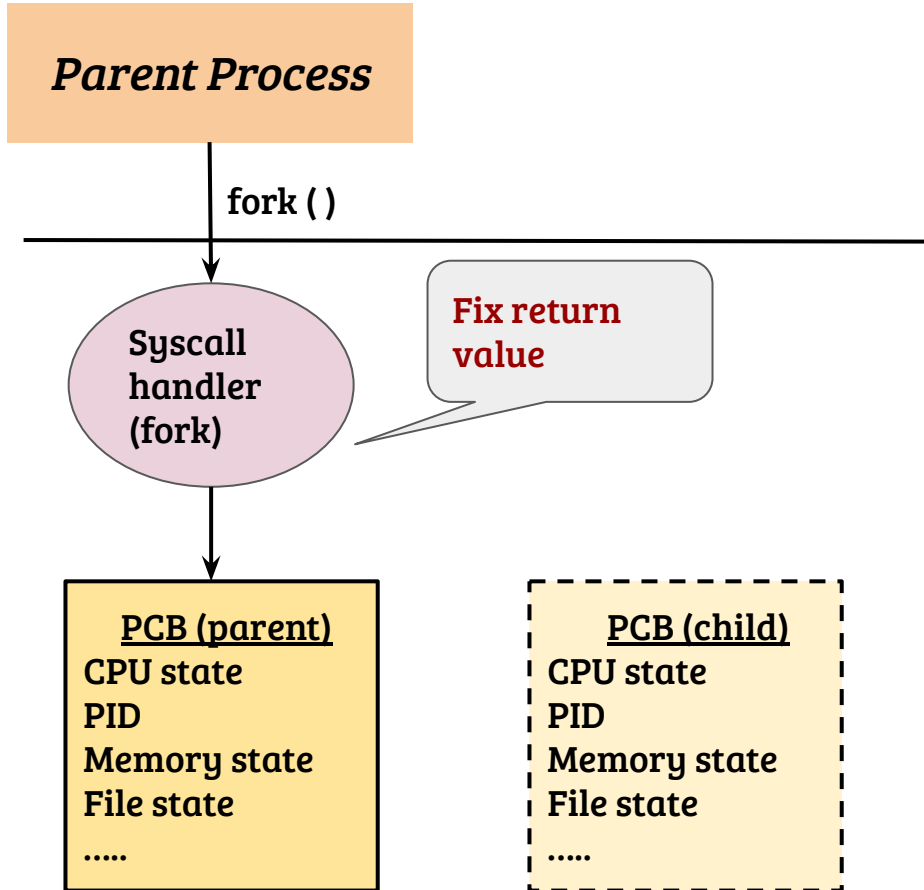

- Child should get '0' and parent gets PID of child as return value. How?
- OS returns different values for parent and child
- When does child execute?

# Typical implementation of fork

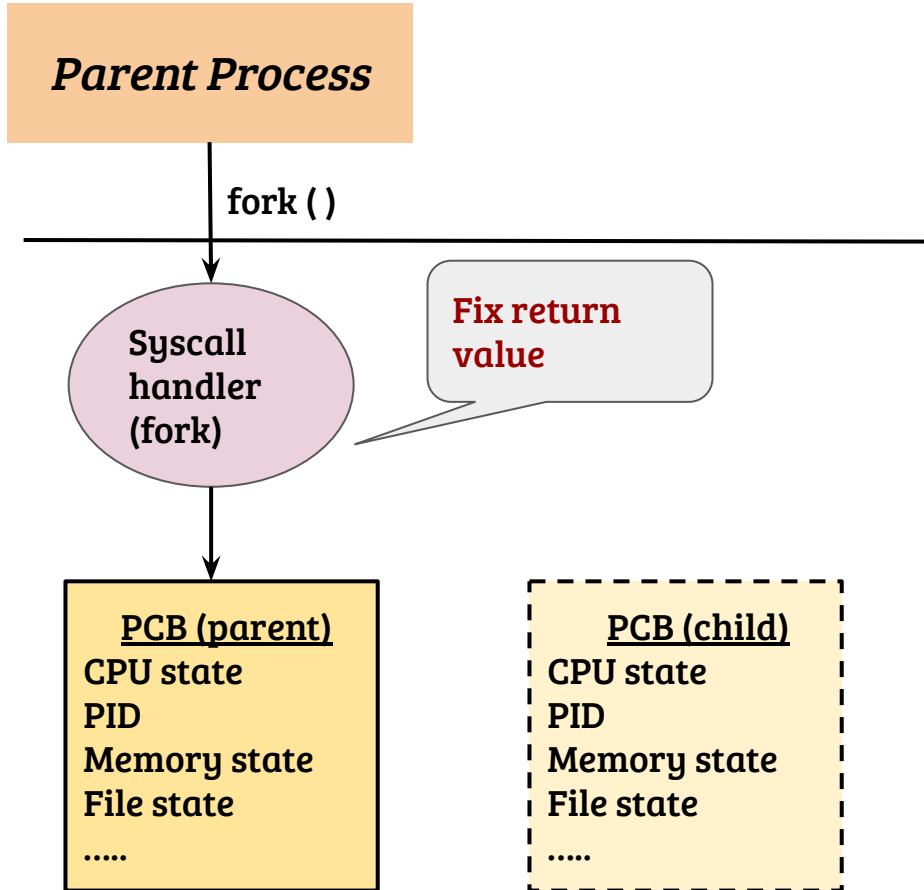

- Child should get '0' and parent gets PID of child as return value. How?
- OS returns different values for parent and child
- When does child execute?
- When OS schedules the child process



# Typical implementation of fork

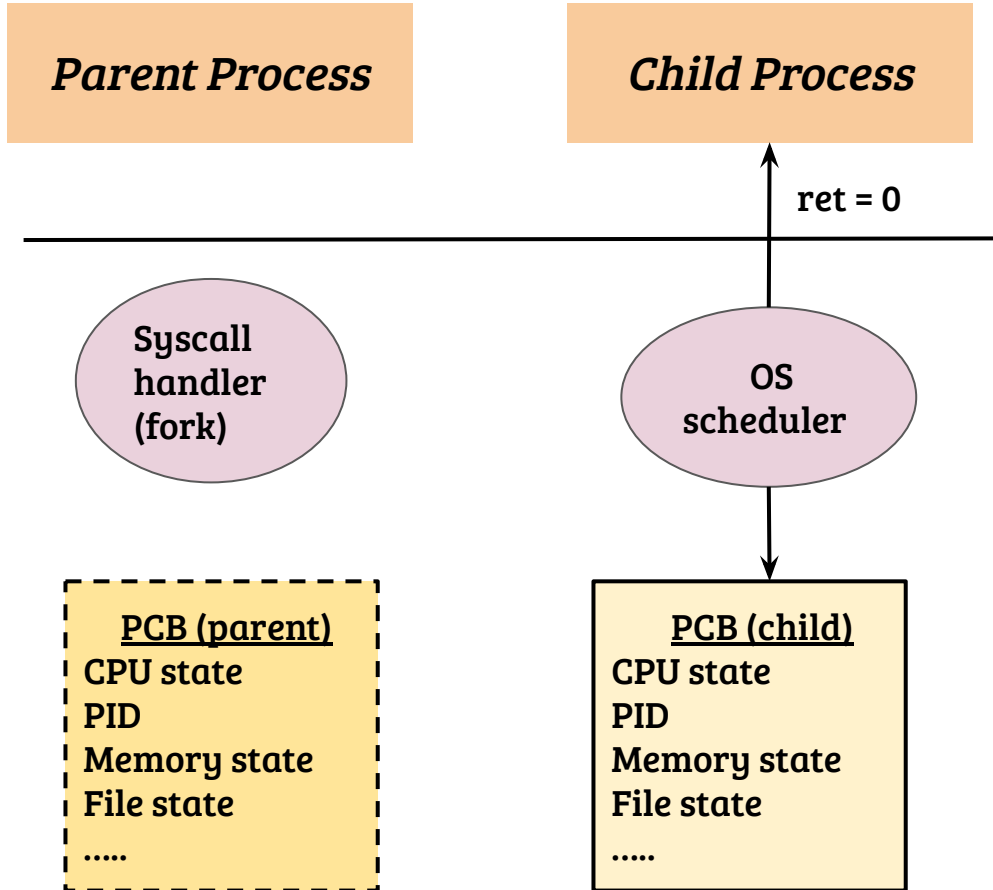

- PC is next instruction after `fork( )` syscall, for both parent and child
- Child memory is an exact copy of parent
- Parent and child diverge from this point

# Load a new binary - `exec( )`

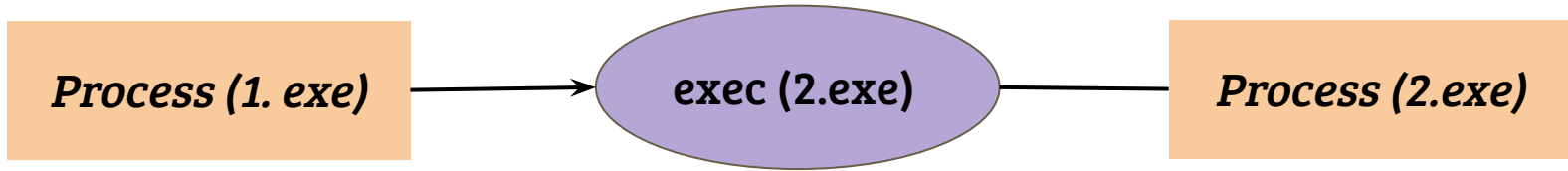

- Replace the calling process by a new executable
  - Code, data etc. are replaced by the new process
  - Usually, open files remain open

# Typical implementation of exec

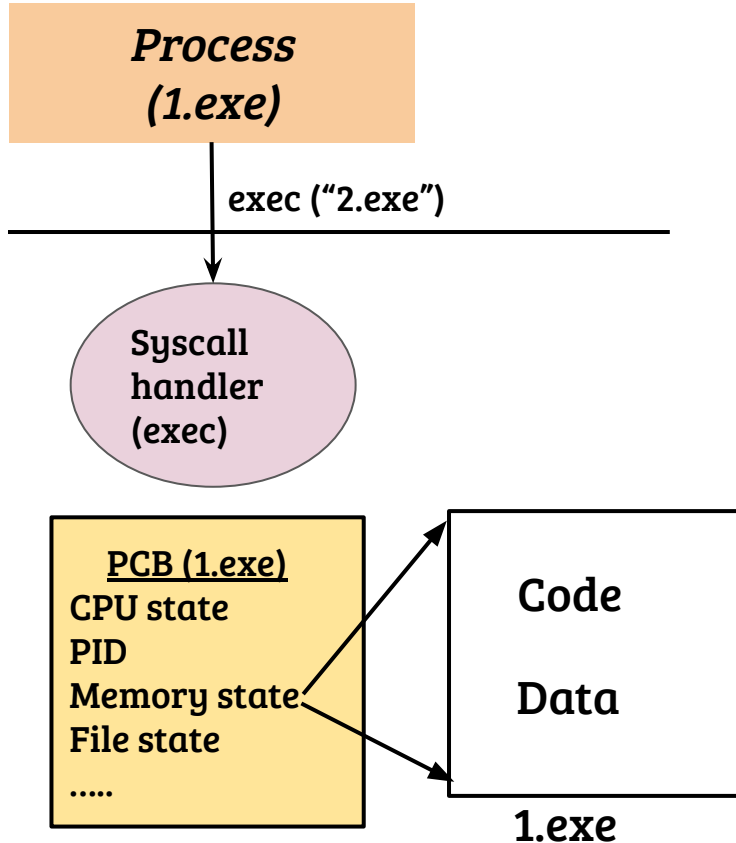

- The calling process commits self destruction! (almost)

# Typical implementation of exec

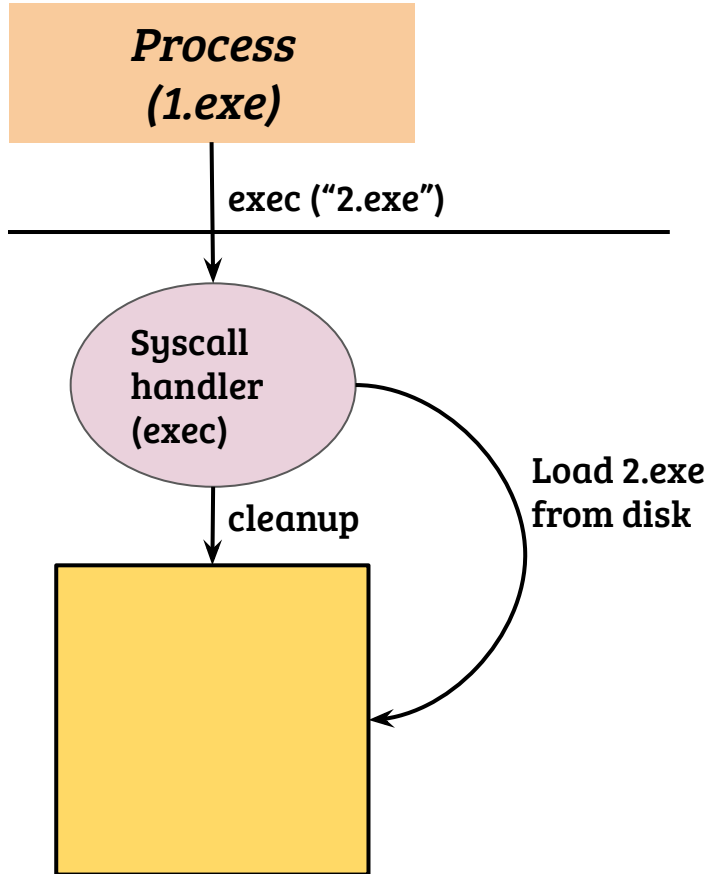

- The calling process commits self destruction! (almost)
- The calling process is cleaned up and replaced by the new executable
- PID remains the same

# Typical implementation of exec

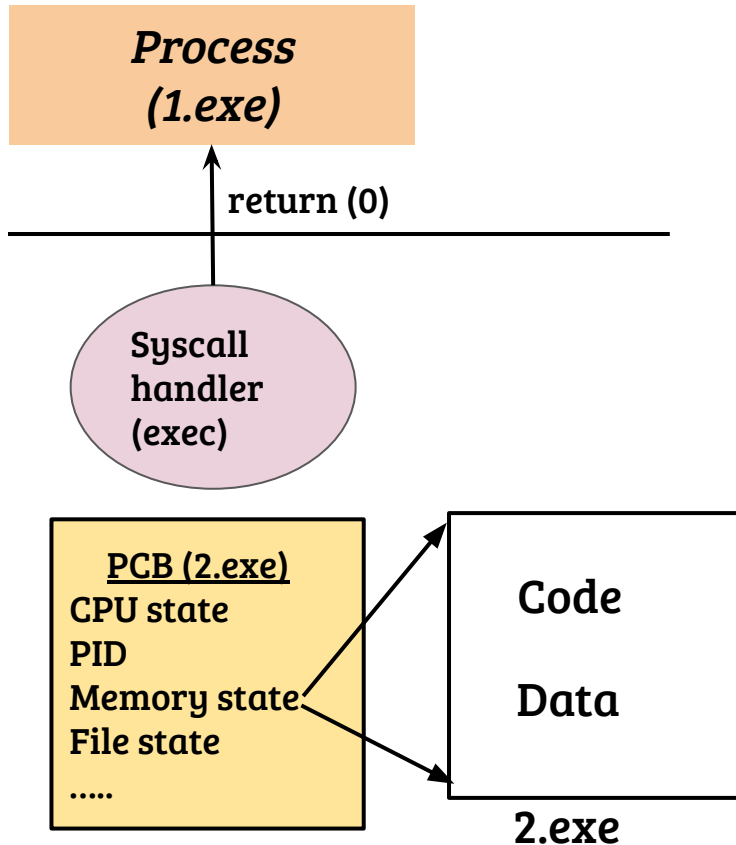

- The calling process commits self destruction! (almost)
- The calling process is cleaned up and replaced by the new executable
- PID remains the same
- On return, new executable starts execution
- PC is loaded with the starting address of the newly loaded binary

# Process creation: What and How?

- How does OS come into action after typing “./a.out” in a shell?
  - System calls invoked to explicitly give control to the OS
  - What exact system calls are invoked?
  - fork( ), exec ( ), wait( ) and exit( )
  - Who invokes the system calls? In what order?
- 

# wait( ) and exit( )

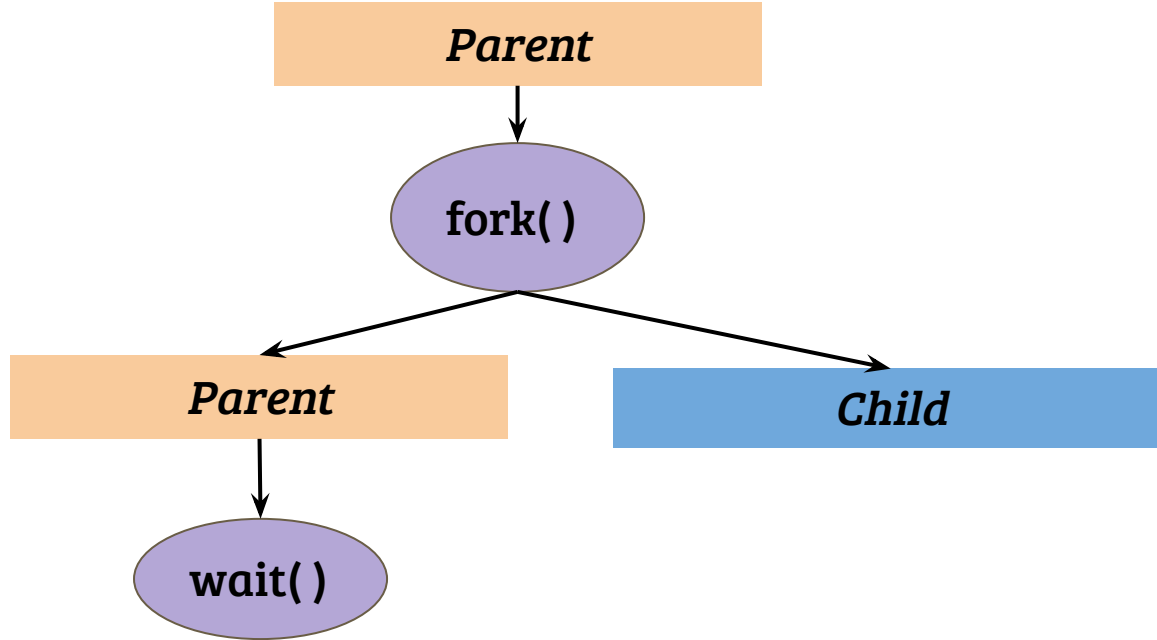

- The wait system call makes the parent wait for child process to exit

# wait( ) and exit( )

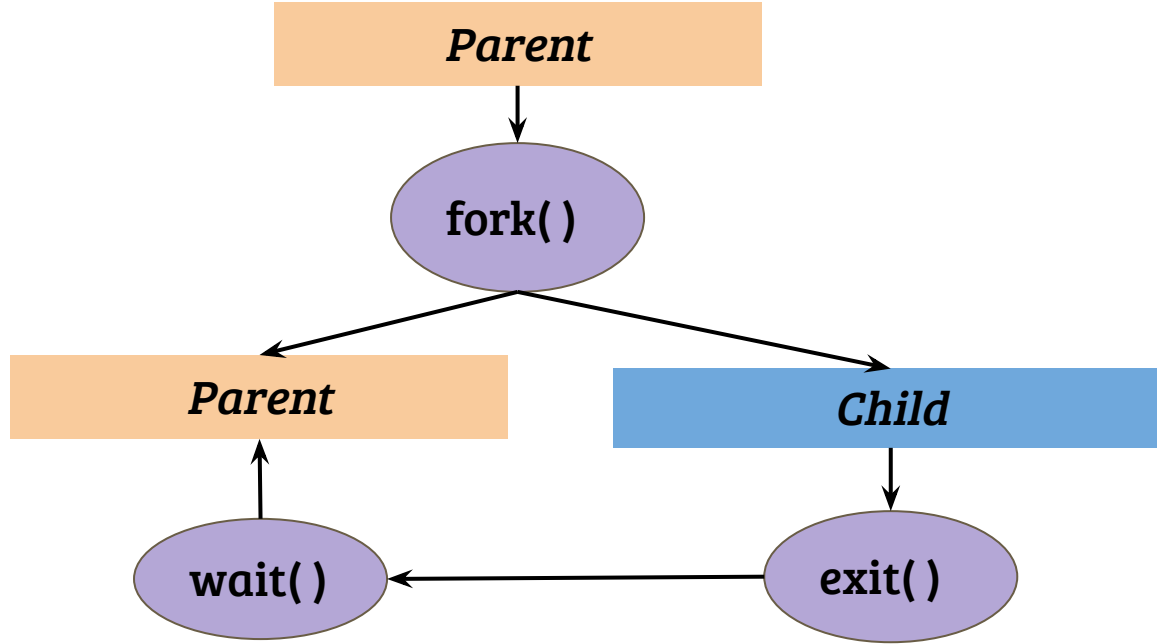

- The wait system call makes the parent wait for child process to exit
- On child `exit()`, the `wait()` system call returns in parent



# Shell command line: fork + exec + wait

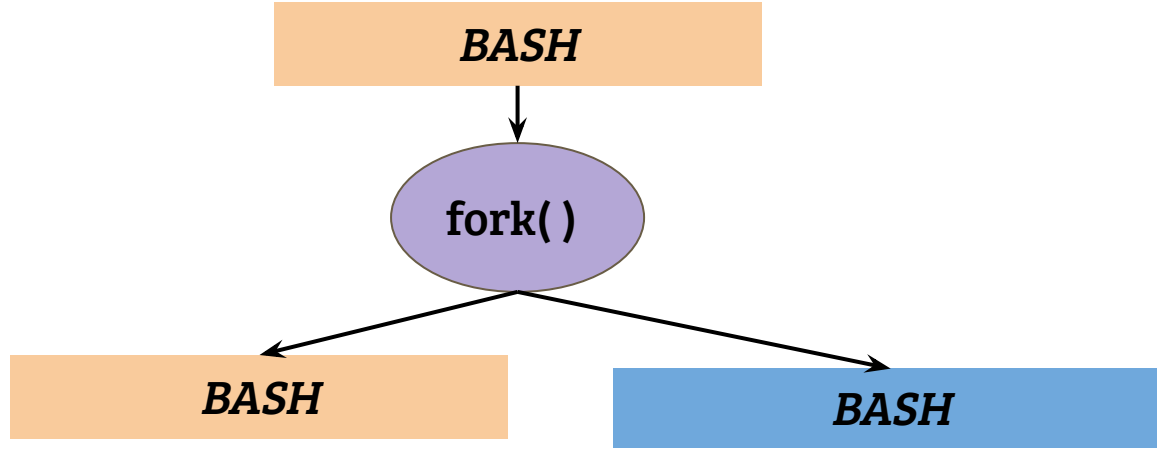

- The BASH process calls `fork()`

# Shell command line: fork + exec + wait

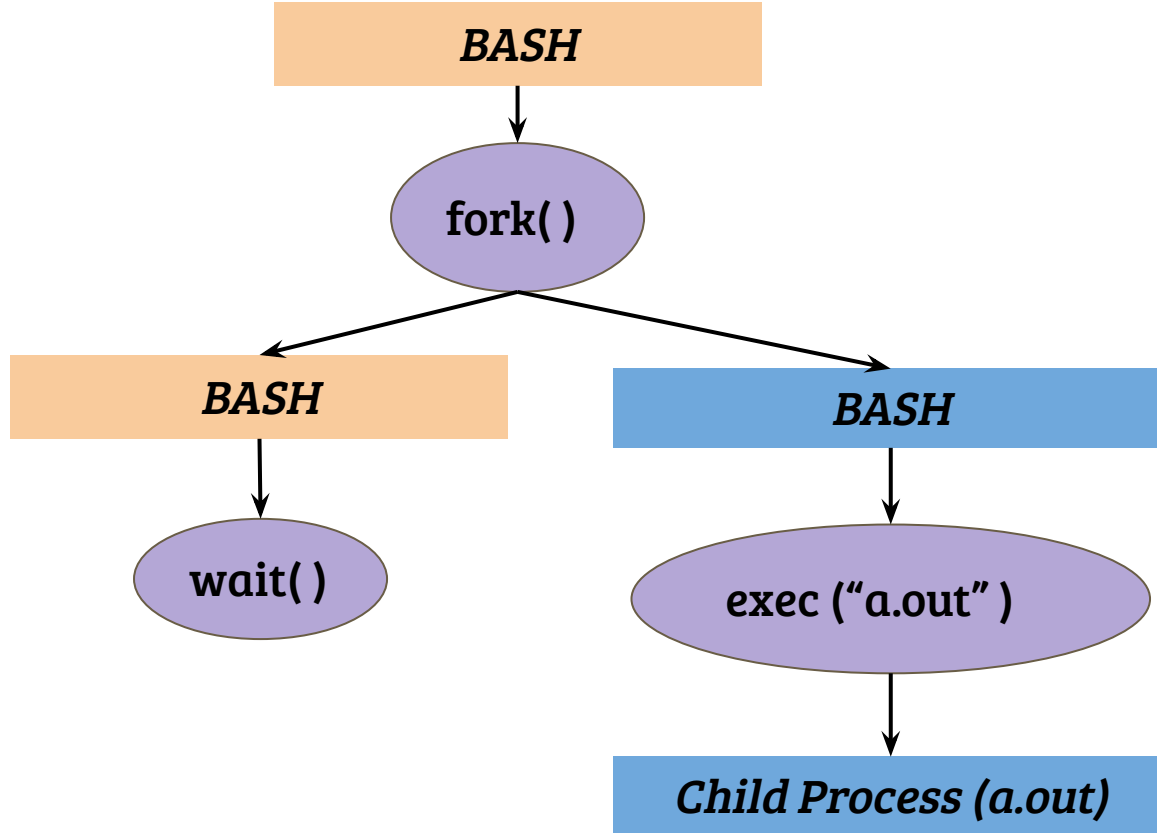

- Parent process calls **wait()** to wait for child to finish
- Child process invokes **exec()**

# Shell command line: fork + exec + wait

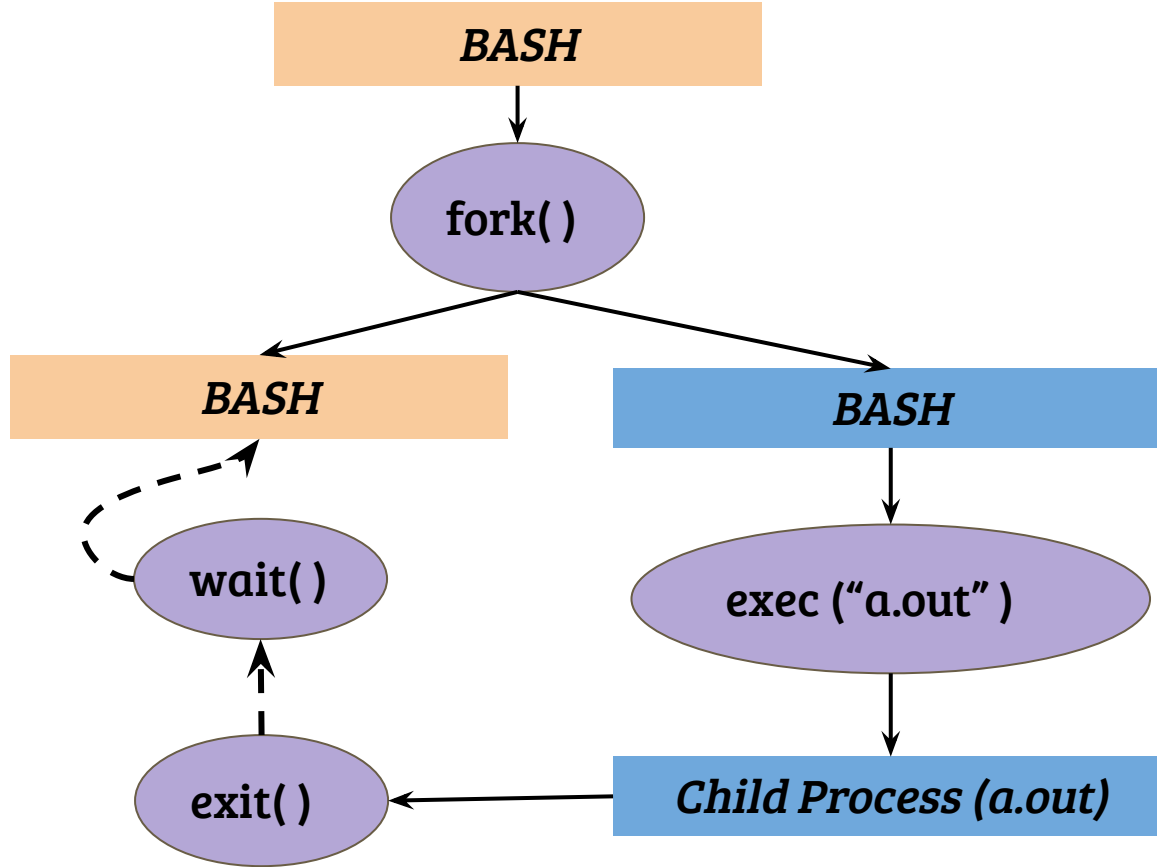

- When child exits, parent gets notified
- The BASH shell is ready for the next command at this point of time

# Process creation: What and How?

- How does OS come into action after typing “./a.out” in a shell?
- System calls invoked to explicitly give control to the OS
- What exact system calls are invoked?
- fork( ), exec ( ), wait( ) and exit( )
- Who invokes the system calls? In what order?
- The shell process (bash process)
- What is the first user process?

# Unix process family using fork + exec

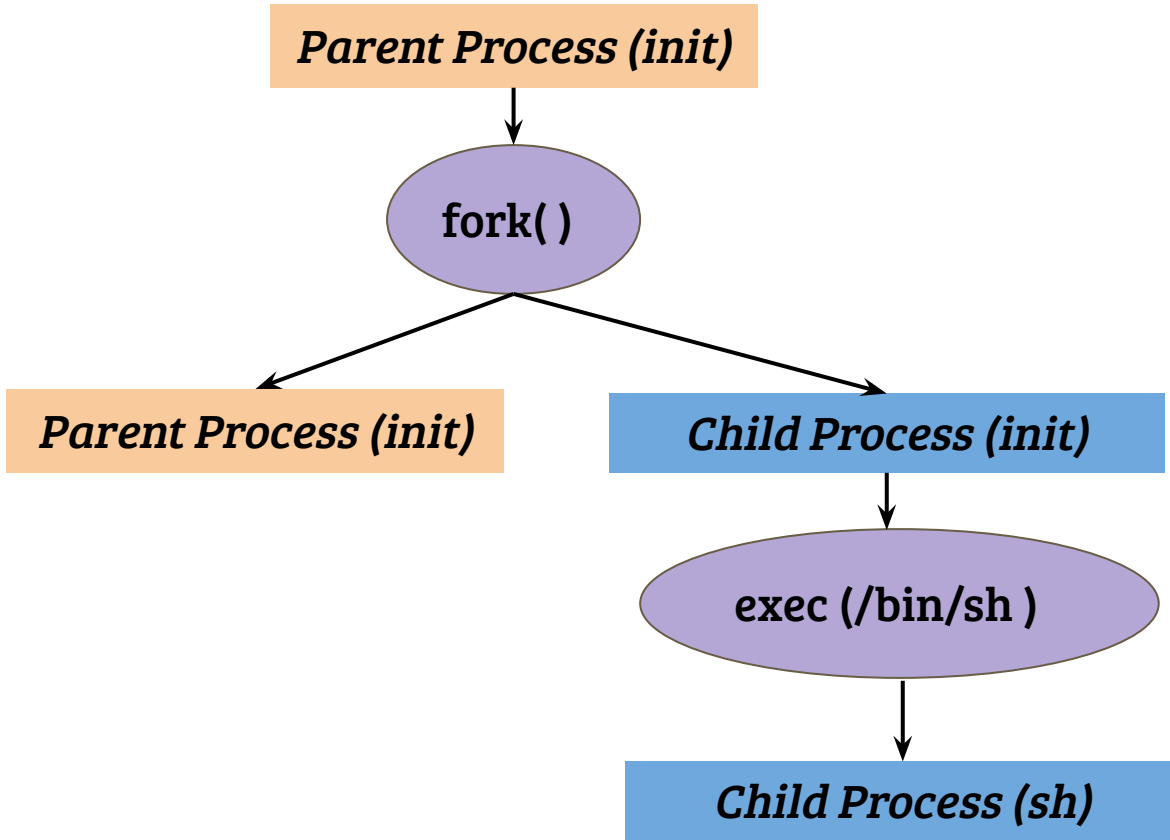

- Fork and exec are used to create the process tree
- Commands: ps, pstree
- See the /proc directory in linux systems

# Process creation: What and How?

- How does OS come into action after typing “./a.out” in a shell?
- System calls invoked to explicitly give control to the OS
- What exact system calls are invoked?
- fork( ), exec ( ), wait( ) and exit( )
- Who invokes the system calls?
- The shell process (bash process)
- What is the first user process?
- In Unix systems, it is called the *init* process
- Who creates and schedules the init process?